

Indian Institute of Information Technology, Allahabad

ELECTRONICS AND COMMUNICATION ENGINEERING DEPARTMENT

Course Name: Electrical Engineering Lab

EXPERIMENT NO: 2

Objective:

- a) To measure the resistance value connected in series and parallel connection.

Materials/ Component Required:

Bread board, Multi meter, Resistors, DC Power supply, Connecting Wires

Theory:

For the series connected resistance the current is common for the each resistance and there is potential drop in individual resistance. The net resistance is the supplied voltage to the current in the circuit. And the individual resistance can be calculated as, potential across each resistance divided by the net current in the circuit.

For the parallel connected resistance the voltage is common for the each resistance and there is change in the current in each resistance depending on its value. The net resistance is the supplied voltage to the net current in the circuit. And the individual resistance can be calculated as, supply potential divided by the current flowing to the measuring resistance in the circuit.

Circuit Diagram:

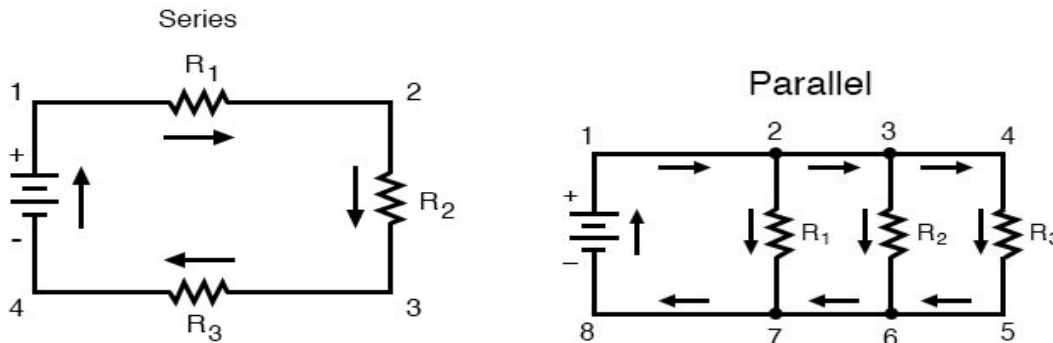

Observation Table:

V_{DC} (v)	I_{DC} (v)	R (Ω) V/I (Series)	R (Ω) V/I (Parallel)

Calculation:

Result:

Series connection

R₁=

R₂=

R₃=

Parallel Connection

R₁=

R₂=

R₃=

Precautions:

- a) Connections should be verified before clicking run button.
- b) The resistance to be chosen should be in K ohm range.
- c) Best performance is being obtained within 50Hz to 1Mhz.